

**SOUTHERN FEDERATION**  
**of**  
**MODEL ENGINEERING SOCIETIES**

Formed from the Federation established in 1970 by Model Engineers for Model Engineers  
A Company Limited by Guarantee in England and Wales No. 9002737  
[www.sfmesc.co.uk](http://www.sfmesc.co.uk)

**Southern Federation Rally**  
**at Guildford MES**  
**Saturday 3rd September 2016**  
***Newsletter Extra—Special Event***

Come and meet members from fellow societies and enjoy the facilities of Guildford MES which include 3½” and 5” raised, and 7¼” ground level tracks, garden railways in 16mm and Gauge 1, and space for model traction engines.

Hot and cold drinks available all day, and a pre-booked mid-day meal.

Presentation of the Australian Association of Live Steamers Shield and Trophy, and also an award for the furthest distance travelled to attend the Rally.

Camping space available.

For further details please contact Jim Wilson via [SFedRally2016@gmes.org.uk](mailto:SFedRally2016@gmes.org.uk), 01252 657914.



Guildford Model Engineering Society  
Stoke Park, London Road, Guildford, Surrey. GU1 1TU  
[www.gmes.org.uk](http://www.gmes.org.uk)

Editor: David Goyder Tel: 023 8042 1201 [newslettereditor@sfmesc.co.uk](mailto:newslettereditor@sfmesc.co.uk)

Views and comments expressed in this publication are not necessarily those of the Southern Federation of Model Engineering Societies



**GUILDFORD MODEL ENGINEERING SOCIETY**  
Stoke Park, London Road, Guildford, Surrey, GU1 1TU

## **Southern Federation Rally, 3rd September 2016**

### Invitation Letter

The Guildford Model Engineering Society (GMES) is pleased to announce that the 2016 Southern Federation Rally will be hosted by GMES and held at our site in Stoke Park, Guildford on Saturday 3<sup>rd</sup> September. An Entry Form accompanies this letter.

The GMES site is located in Guildford close to the A3 and hence close to Junction 10 of the M25. Our facilities include track circuits of 1405ft combined 3½" and 5" gauge raised track, and 990ft of 7¼" gauge ground level track, and the relevant track clearance diagrams are provided overleaf. We have a good number of steaming bays with easily accessible unloading ramps. Extensive 16mm Garden Railway and Gauge 1 tracks are also available should anyone require this facility. Additionally, there is a short length of 2½" Gauge track.

We intend to open the site from early afternoon on the Friday (2<sup>nd</sup> September) for those wishing to arrive early, and the tracks will be available for anyone wishing to use them. Unlike previous years, the day following the Rally (Sunday 4<sup>th</sup> September) is not a public running day at Guildford but is scheduled as a members running day. Anyone wishing to stay over and participate would be welcome but there is no public passenger hauling.

GMES has a number of 3½" and 5" gauge raised track driving trolleys, but it might be helpful if attendees could bring their own provided that they comply with the GMES track diagrams.

We hope to provide a bacon butties on the Saturday morning, and a pre-booked mid-day meal later on. Hot or cold drinks will be available in the Clubhouse on a serve yourself basis throughout the event.

In terms of accommodation, the GMES site has limited camping space which will be allocated on a first come first served basis, and please note that we may be able to provide a limited number of electrical hook-ups for fridges and LED lighting, but we do not have toilet disposal facilities. For those of you who would prefer hotel accommodation, there is a Travelodge hotel just down the road from our site, and there are a number of other hotels in the vicinity.

Please return your application form to Bryan Finch either by post to the address given on the form or by e-mail to him via [SFedRally2016@gmes.org.uk](mailto:SFedRally2016@gmes.org.uk) by the 26<sup>th</sup> August 2016 at the latest. Please let us know if for any reason after returning the form, you find that you will be unable to attend.

If you have any questions, please contact either myself on 01252 657914 or Bryan Finch on 01483 858856.

Further information about GMES and its location can be found on our website <http://www.gmes.org.uk>

Kind regards,

Jim Wilson  
GMES Southern Federation Rally Chairman

**Please keep this letter - Important stuff overleaf**

## GMES Track Diagrams

GROUND LEVEL TRACK CLEARANCE DIAGRAM

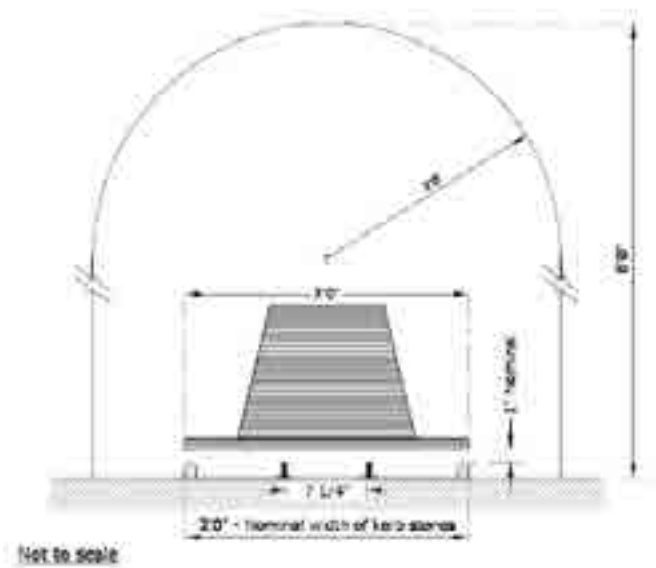

RAISED TRACK CLEARANCE DIAGRAM

Applies to passenger carrying tracks only,  
not applicable to steaming bays or carriage shed.

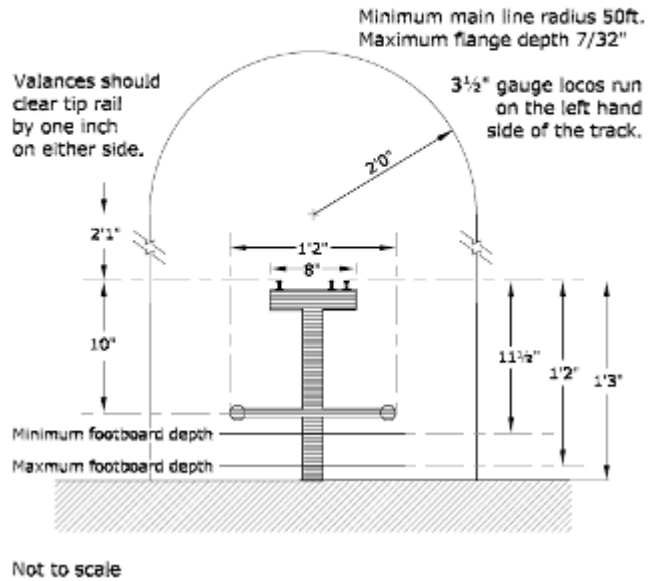

## Conditions of entry

Please note that GMES intends to conduct the 2016 Southern Federation Rally with the very minimum of rules, but would like to draw your attention to the following requirements based on our experience of past events such as this.

1. All visitors must be signed in.
2. Steam locomotives must have a current boiler certificate and the entrant must provide proof of third party insurance. These documents must be produced when booking in, so that they can be checked and recorded before steam is raised on your locomotive.
3. Track Marshall's and Steward's decisions are final.
4. Visitors must conduct themselves so as not to endanger or inconvenience others.
5. Dogs must be kept on a lead at all times, and all poops must be scooped.
6. Drivers under the age of 17 may drive locomotives under certain conditions at the discretion of the GMES Track Marshall, and permission must be granted beforehand.

## GMES site location – Postcode GU1 1TU



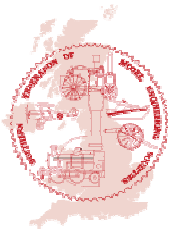

Guildford Model Engineering Society Ltd.,  
Stoke Park, London Road, Guildford, Surrey. GU1 1TU



## Southern Federation Rally, 3 September 2016

### Contact Details (Please print clearly)

Name .....

Address.....

.....Postcode .....

Tel. No. ....Mobile No.....E-mail.....

Club / Society .....

### Description of your entry

Please indicate the type of locomotive, and whether it will be available for running, or static display.

Details of Model(s)	Motive Power Steam / Electric /	Gauge 16mm / G1 / 2½"	Vacuum Brakes? Y / N	Static or Running?

Will you be bringing a driving trolley? Yes / No

### Attendance Details

How many people will be in your party, including yourself .....

Will you be requiring the Saturday mid-day meal? Yes / No If YES – how many people.....  
(This will give us an indication of numbers, firm orders will be taken on arrival)

### Camping

If you wish to camp, please indicate type of unit (please delete as appropriate):-

Tent, Trailer Tent, Caravan, Motor Caravan, Other – please specify.....

Dimensions of unit: length.....m width.....m

When will you be arriving? pm Friday / Saturday. When will you be departing? Saturday / am Sunday

I wish to attend the 2016 Southern Federation Rally and I agree to abide by the terms, conditions and guidelines expressed in the Rally Invitation Letter.

Signed.....Dated.....

Please return this application form as soon as possible but not later than 26 August 2016, to Bryan Finch, either by post to 1 Oakfields, Guildford, Surrey, GU3 3AS, or by e-mail via [SFedRally2016@gmes.org.uk](mailto:SFedRally2016@gmes.org.uk) Telephone 01483 858856